

THIS DRAWING IS UNPUBLISHED. RELEASED FOR PUBLICATION, 19 .
 © COPYRIGHT 19 BY AMP INCORPORATED. ALL INTERNATIONAL RIGHTS RESERVED.

LOC		DIST		REVISIONS				DATE	APPD
P	F	ZONE	LTR	DESCRIPTION					
G	14			C	REV & REDRAWN PER 0720-0061-93			3-24-93	DA P

METRIC
 DIMENSIONS LISTED IN mm [INCHES]

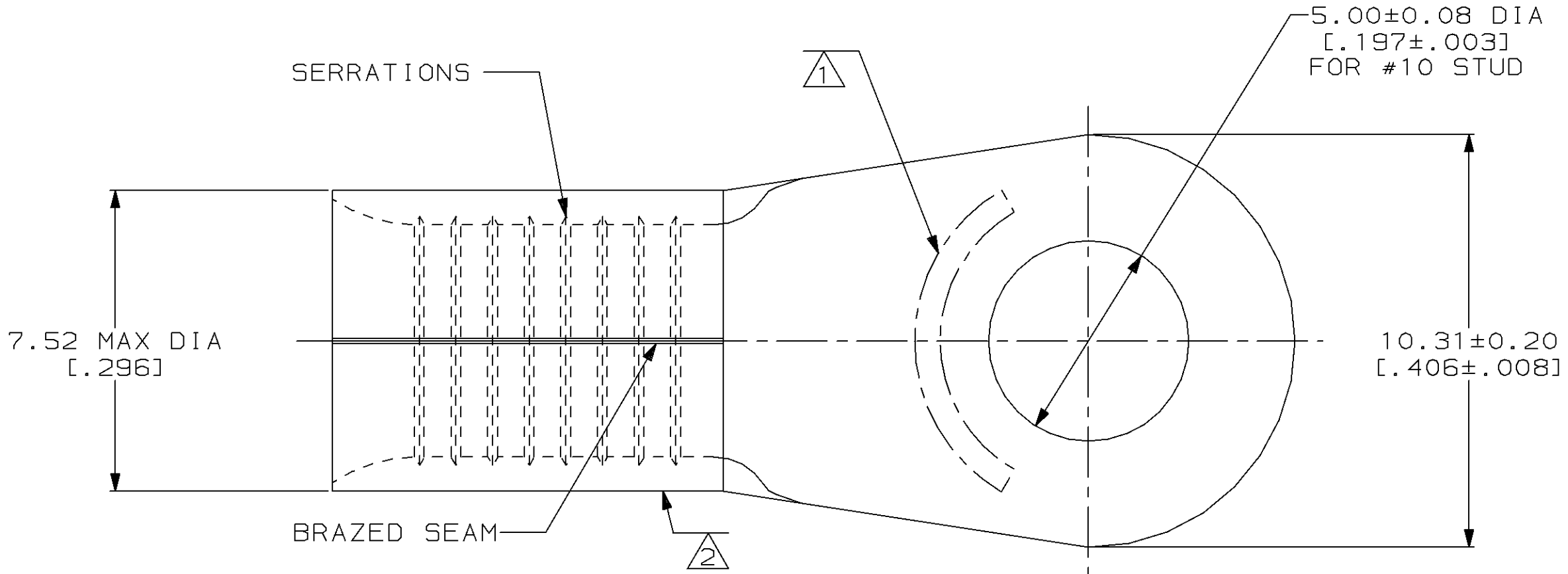

AMP WIRE RANGE	UL Listed
8 AWG SOLID OR STRANDED	NOT APPLICABLE
SR LR7189 Certified	MILITARY P/N AND CLASS
NOT APPLICABLE	NOT APPLICABLE

- ① STAMP AMP 8 APPROX AS SHOWN
- ② WIRE BARREL COLOR CODED ORANGE TO DENOTE NICKEL MATERIAL

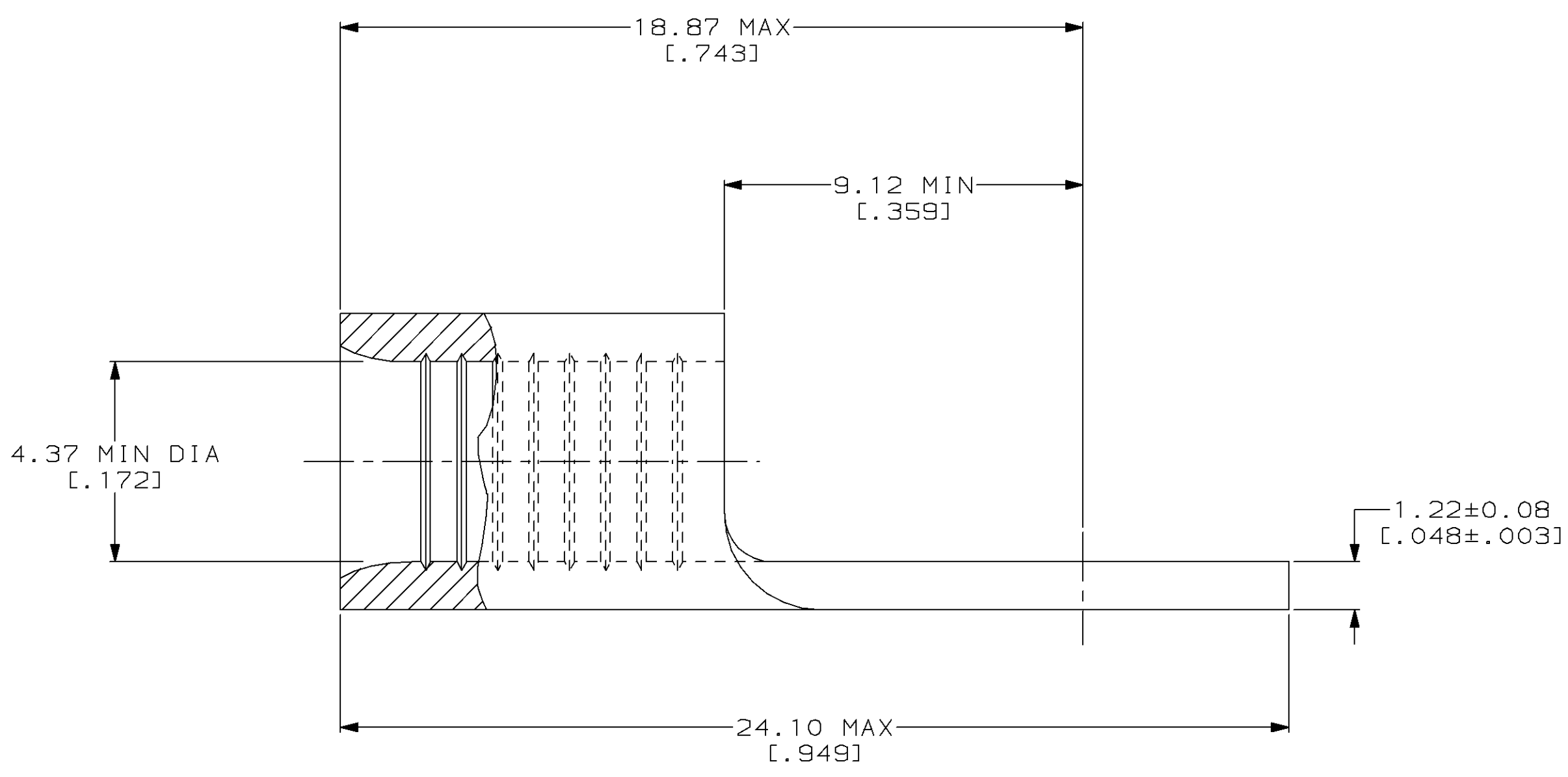

328822

PART NO

AMP INCORPORATED
 CUSTOMER SERVICE SYSTEMS

MAX RECOMMENDED OPERATING TEMPERATURE:
 649°C MAX

DO NOT SCALE PRINT. UNLESS SPECIFIED
 DIMENSIONS IN mm [INCHES]
 TOLERANCES ON:
 2 PLC DEC ± -
 3 PLC DEC ± -
 ANGLES ± -

DR 3-24-93
 TA BRINKMAN
 CHK 3-24-93
 DA PATTERSON

AMP AMP Incorporated
 Harrisburg, PA 17105-3608

FOR ADDITIONAL PRODUCT INFORMATION OR COPIES OF DRAWINGS AND TECHNICAL DOCUMENTS

PRODUCT INFORMATION CENTER
 1-800-522-6752

VOLTAGE RATING:
 NOT APPLICABLE

MATERIAL
 NICKEL PER ASTM B-162 ANNEALED

APPD 3-24-93
 DE MILLER
 APPD 3-24-93
 JL MECKLEY
 PRODUCT SPEC -

NAME
 TERMINAL, RING TONGUE, HIGH TEMPERATURE, STRATO-THERM™

FOR APPLICATION TOOLING INFORMATION

TOOLING ASSISTANCE CENTER
 1-800-722-1111

WIRE CROSS SECTIONAL AREA RANGE:
 6.64-10.5MM² [13,100-20,800] CIR MILS
 SOLID OR STRANDED

FINISH
 -

APPLICATION SPEC
 -

SIZE
 CAGE CODE 00779
 DRAWING NO C=328822

FOR ORDER ENTRY

1-800-526-5142

THIS DRAWING IS A CONTROLLED DOCUMENT FOR AMP INCORPORATED. IT IS SUBJECT TO CHANGE AND THE CONTROLLING ENGINEERING ORGANIZATION SHOULD BE CONTACTED FOR THE LATEST REVISION.

WEIGHT
 -

SCALE 8:1

SHEET 1 OF 1